

MERITOR WABCO

Installation Guide

Installing the FRK 08-10086 Hydraulic Compact Unit (HCU) on International School Buses

Hazard Alert Messages

Read and observe all Warning and Caution hazard alert messages in this publication. They provide information that can help prevent serious personal injury, damage to components, or both.

WARNING

To prevent serious eye injury, always wear safe eye protection when you perform vehicle maintenance or service.

Park the vehicle on a level surface. Block the wheels to prevent the vehicle from moving. Support the vehicle with safety stands. Do not work under a vehicle supported only by jacks. Jacks can slip and fall over. Serious personal injury and damage to components can result.

Release all air from the air systems before you remove any components. Pressurized air can cause serious personal injury.

The full power brake system is a pressurized system that achieves pressures of up to 2,320 psi. This pressure is not reduced by switching the ignition off or removing battery power. Prior to servicing this system, the depressurization procedures must be performed exactly as presented. Failure to depressurize the system may result in personal injury or death. Note: The depressurization procedure can be found in Step 2.

CAUTION

The HCU hydraulic power brake system is a complex device that provides optimum efficiency and operation. If the system sustains damage, or a component malfunctions and requires replacement, the replacement procedures provided by Meritor WABCO must be followed exactly with the associated steps performed in the order presented.

Hydraulic brake fluid is a caustic substance. Contact with the hydraulic brake fluid can cause skin irritation. Do not let hydraulic brake fluid touch any painted surfaces, as it will remove the paint. Hydraulic brake fluid may also damage certain non-metal surfaces. Do not let fluid contact brake pads, shoes, rotors or discs.

Before disposing of used components, verify the warranty status. Contact ArvinMeritor OnTrac at 866-668-7221 for instructions.

How to Obtain Additional Maintenance and Service Information

Refer to Maintenance Manual 0401, Meritor WABCO Hydraulic Power Brake (HCU) System. To obtain this publication, visit Literature on Demand at arvinmeritor.com. Meritor WABCO publications are also available on our website:

www.meritorwabco.com

How to Obtain Kits

Contact ArvinMeritor OnTrac at 866-668-7221 for authorization.

Hydraulic Compact Unit Installation Kit

Field Repair Kit Contents

Components	Quantity	Description
478 407 924 2	1	Service Part Prefilled HCU, Full 10 Coil
891 490 837 4	4	Mounting Screws
899 759 875 4	4	Mounting Bushings, Aluminum
100 100 103 4	1	Small Screwdriver
TP-0913	1	Instruction Sheet
899 201 602 4	1	Silver Identifying Label, FRK Unit
100 001 013 4	1	Red Tag
100 001 016 4	1	Return Shipping Label

How to Obtain Tools

To obtain Meritor WABCO TOOLBOX™ Software, call 1-800-328-6657. Ask the service representative to help you select any cables or adapters that may be required to run the software.

For ITE or SPX kit number ZTSE4757 which includes the pressure supply valve socket and pressure bleeder kit with regulator, visit <http://international.spx.com>.

Quick Installation Guide

This bulletin provides instructions for installing the new Field Repair Kit (FRK) 08-10086 Hydraulic Compact Unit (HCU) on International school buses. This kit is to be used if damage or a failure occurs in the HCU pumps, motors or motor bearings. The service part prefilled HCU full 10 coil unit in the kit, sometimes referred to as a Hydraulic Power Brake (HPB) unit, includes an ECU mounted directly to the HCU.

Correct installation of the new HCU requires the following procedures to be performed in their entirety in the exact sequence provided in this bulletin. This 6-step Quick Installation Guide is for those technicians with experience in Hydraulic Power Brake (HPB) installation. Detailed instructions for these procedures can be found in the following pages.

Step 1 - Inspect the ECU Connector Secondary Locks and Terminals

1. Check for proper installation of secondary locks.
2. Inspect the connectors for terminal corrosion.

CAUTION

The ECU connector secondary locks and terminals **MUST** be inspected and in good condition before the new HCU is installed. You **MUST** repair or replace these components as necessary before you install the new HCU. If the components are not in proper condition, you can damage the new HCU when you install it.

Step 2 - Remove the Old HCU

1. De-pressurize the system.
2. Drain all brake fluid from master cylinder reservoir.

CAUTION

You **MUST** drain all the brake fluid from the master cylinder reservoir as described in this bulletin to ensure the unit operates correctly when installed.

3. Disconnect and remove the HCU.

Step 3 - Prepare the New FRK HCU for Installation

1. Install the parking brake supply valve and adapter.
2. Install the HCU reservoir.
3. Install the mounting brackets.

Step 4 - Install the New FRK HCU on the Vehicle

Step 5 - Pressure Bleed the New FRK HCU and the Entire HPB System

Step 6 - System Checkout

Step 1 - Inspect the ECU Connector Secondary Locks and Terminals

Inspect the Secondary Locks

1. Wear safe eye protection.
2. Park the vehicle on a level surface. Apply the parking brake. Ensure that the ignition is turned OFF.
3. Block the wheels to prevent the vehicle from moving.
4. Disconnect the battery.
5. Clean any loose debris from the ECU connectors.
6. Open the latches and remove the 31-pin and 2-pin connectors from the ECU. Figure 1.

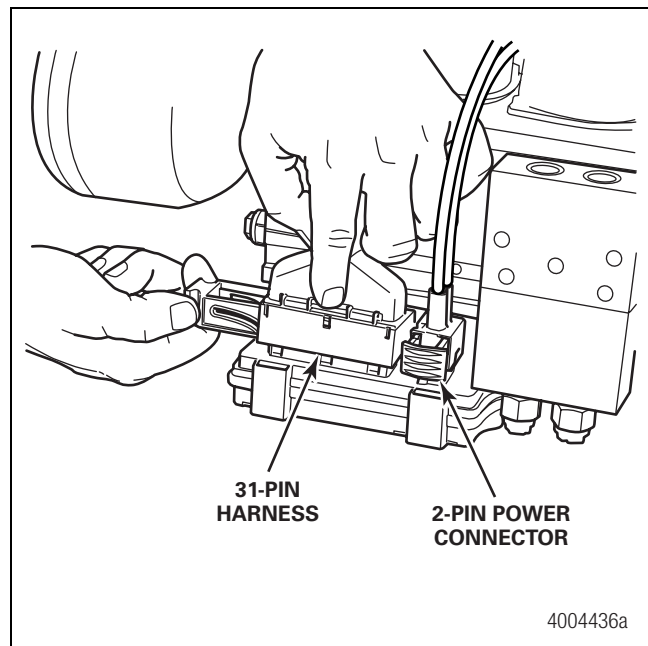

Figure 1

- View the terminal side of the 31-pin connector. Check for proper installation of the two secondary locks installed at opposite sides of the connector. The secondary locks assist in securing the terminals in the connector shell. Correct installation of the secondary locks is critical for proper seating of the connector on the HCU ECU. Figure 2, Figure 3 and Figure 4.

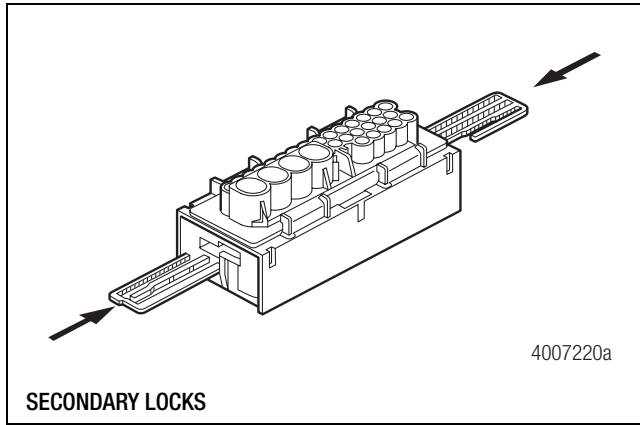

Figure 2

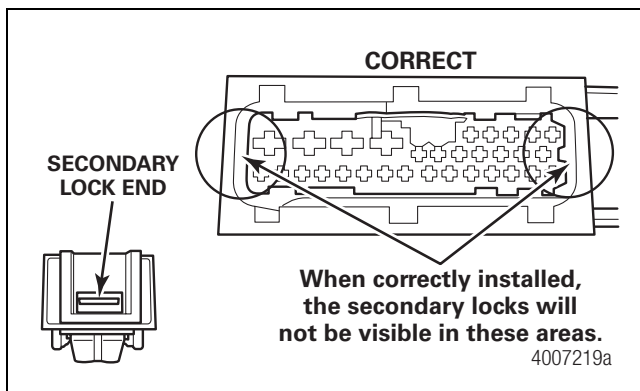

Figure 3

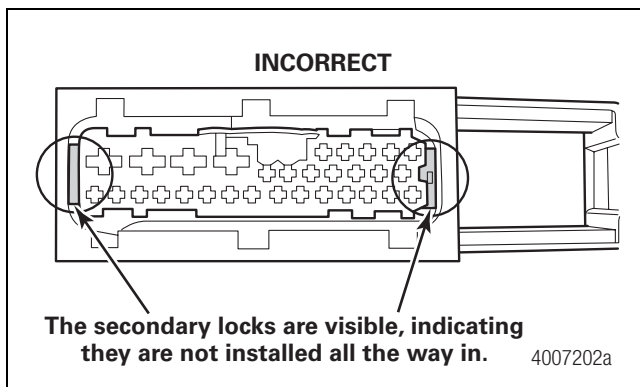

Figure 4

- If necessary, use the screwdriver in the kit to push the secondary locks on each side in until completely seated. Verify each lock is installed correctly and not covering the seal. Figure 5.

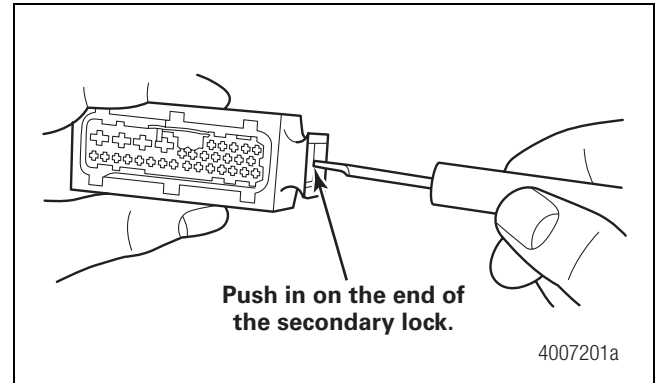

Figure 5

Inspect the ECU Terminals

- Inspect for terminal corrosion on the 31-pin and 2-pin ECU connectors.
- If corrosion is found, contact Navistar Tech Services to determine if the entire harness or individual terminals need to be replaced.

NOTE: Do not reinstall the connectors after they have been inspected. Leave them disconnected from the ECU until instructed to reinstall them in Step 4.

Step 2 - Remove the Old HCU

De-pressurize System

- Ensure the vehicle is parked on a level surface, the parking brake is applied and the ignition is turned OFF. Make sure the wheels are blocked to prevent the vehicle from moving.
- Verify the battery is disconnected and both ECU harness connectors have been removed from the ECU.
- Fully apply the brake pedal a minimum of 30 times to decrease the pressure in the system.

Drain Brake Fluid from the Master Cylinder Reservoir

- Attach a pinch clamp to the low pressure hose near the HCU lower reservoir inlet. Figure 6.

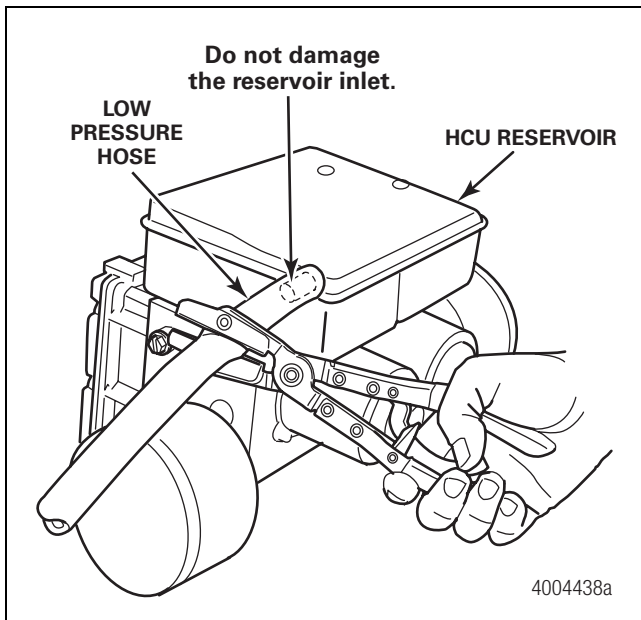

Figure 6

2. Remove the low pressure hose from the HCU reservoir.
3. Remove the cap from the master cylinder. Place the opened end of the low pressure hose in a container and remove the pinch clamp. The fluid in the master cylinder reservoir will drain into the container.
4. Reinstall the master cylinder cap.
5. Thoroughly clean the area around the two relay valve fittings. These attach the two brake lines from the master cylinder to the HCU. Figure 13 and Figure 14.
6. Loosen and remove the two fittings from the HCU and place the opened ends of the brake lines in a container.
7. Remove the master cylinder cap and the remaining fluid in the master cylinder will drain into the container. Properly dispose of the old brake fluid.
8. Once the fluid drains from the master cylinder reservoir, cap the brake lines to ensure contamination does not enter the brake system. Reinstall the master cylinder cap.

Disconnect and Remove the HCU

1. Thoroughly clean the area around the five remaining brake line fittings before beginning the removal procedure. Figure 13 and Figure 14.
2. Loosen the fittings. As the fittings are loosened and the brake lines are removed, cap all lines to ensure contamination does not enter the brake system. Mark the brake lines to ensure proper assembly to the new unit.
3. Disconnect the electrical connector from the parking brake pressure supply valve.

4. While supporting the HCU, loosen and remove the four nuts (two per side) that hold the HCU mounting brackets to the frame rail of the vehicle. Remove the HCU, with mounting brackets attached, from the vehicle. Figure 7.

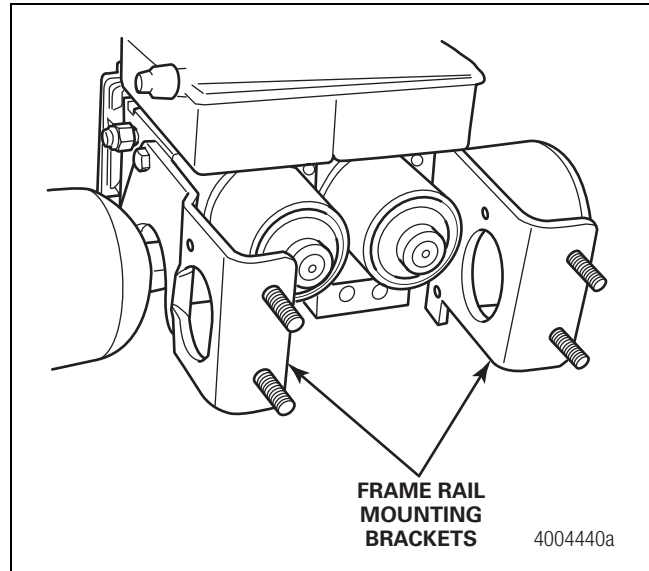

Figure 7

5. With the HCU off the vehicle, loosen and remove the two bolts that hold the HCU to the front and rear mounting brackets. Remove the mounting brackets from the HCU.
6. Remove the four bushings inside the brackets and replace them with the new ones provided in the repair kit.
7. Unscrew the black plastic nut from the pressure supply valve. Remove the coil and O-ring. Figure 8.

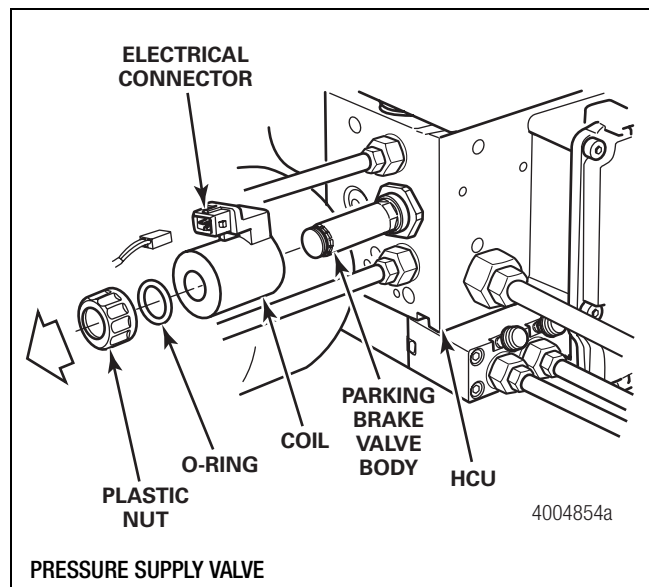

Figure 8

- Use a clean rag to carefully clean the outside of the HCU and the pressure supply valve.
- Use a wrench, Snap-On part number A121, to remove the pressure supply valve from the HCU. Figure 9.

NOTE: Do not attempt to use a regular 17 mm wrench to remove the pressure supply valve from the HCU body. Use Snap-On wrench part number A121 to remove the valve.

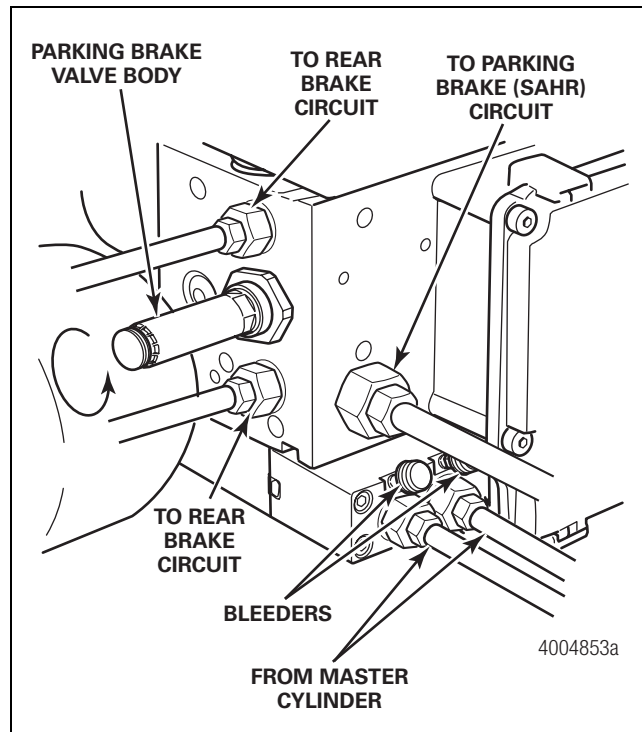

Figure 9

Step 3 - Prepare the New FRK HCU for Installation

⚠ CAUTION

The replacement HCU is pre-charged with brake fluid to ensure successful bleeding. To prevent fluid loss, do not remove the protective caps until you are ready to connect the brake lines. Damage to components can result.

Install the Parking Brake Supply Valve and Adapter on the New HCU

- Remove the plug from the parking brake pressure supply valve port on the new HCU.
- Use DOT 3 OR DOT 4 brake fluid to lubricate the O-rings on the parking brake pressure supply valve that was removed from the old HCU. Refer to the vehicle specification sheet to determine which fluid to use.

- Position the parking brake pressure supply valve onto the HCU. Use a wrench, Snap-On tool number A121, to tighten the valve to 27-34 ft-lb (40-50 N•m). Figure 9.
- Place the coil, O-ring and black plastic nut onto the parking brake pressure supply valve. Use a 12-point socket wrench to tighten the black plastic nut to 26.5 in-lb (3 N•m). Figure 10.

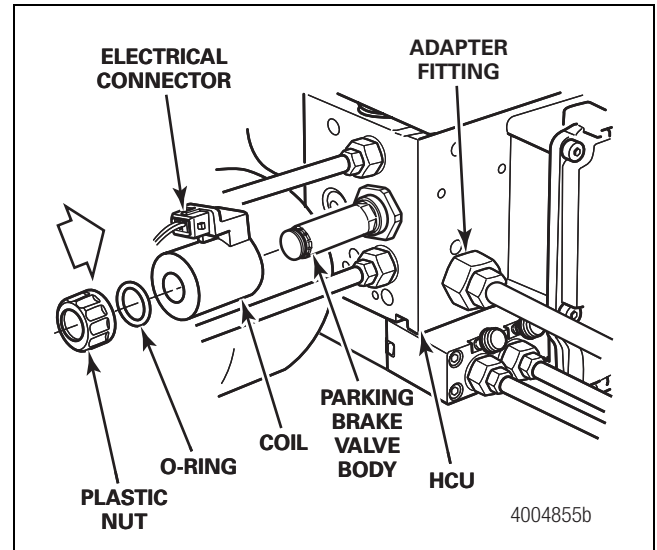

Figure 10

- Remove the plug from the parking brake port in the new HCU and replace it with the adapter fitting from the old unit. Make sure the adapter fitting is clean before installation. Tighten the adapter fitting to 22-25 ft-lb (30-35 N•m).

Install the Reservoir

- Remove the top plastic cover from the new HCU.
- Use new clean DOT 3 OR DOT 4 brake fluid to lubricate the reservoir grommets. Refer to the vehicle specification sheet to determine which fluid to use.
- Position the new reservoir provided in the kit on the HCU and verify the orientation. The mounting screw holes must line up and the inlet port for the low pressure hose must face the front of the HCU. Figure 11.

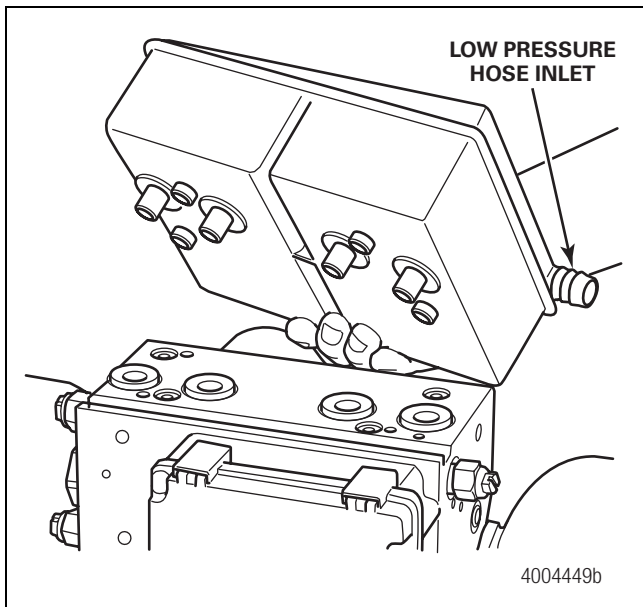

Figure 11

4. Install the new reservoir by pressing it carefully and completely into the grommets in the ports. Figure 12.

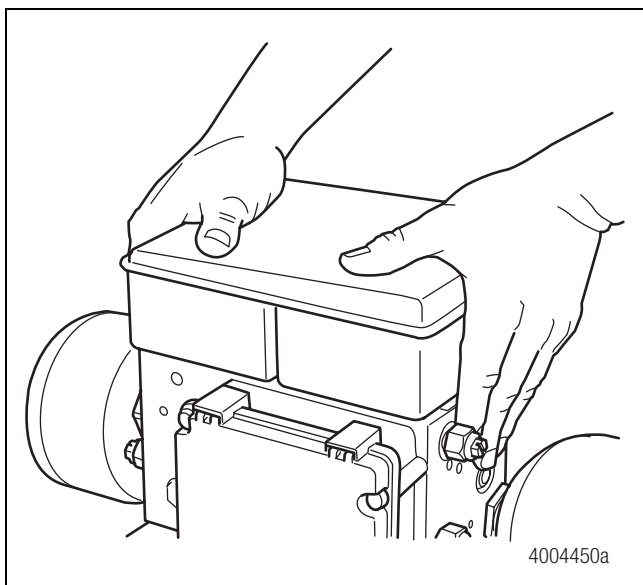

Figure 12

5. Use the four new mounting screws provided in the kit to attach the reservoir to the HCU. Use a number 4 Phillips-head screwdriver to tighten the screws to 43-60 in-lb (5-7 N•m).

Install the Mounting Brackets on the New HCU

1. Attach the two HCU mounting brackets onto the new HCU using the four replacement bolts and aluminum bushings provided in the kit.
2. Tighten the bolts to 32-34 ft-lb (43-46 N•m).

Step 4 - Install the New HCU on the Vehicle

1. Attach the two mounting brackets to the frame rail of the vehicle. Tighten the nuts to 79.7-99.6 ft-lb (108-135 N•m).
2. Connect the seven brake lines to the new HCU. Remove the protective cover before attaching the line. Check the line markers to ensure correct installation on the HCU. Figure 13 and Figure 14.

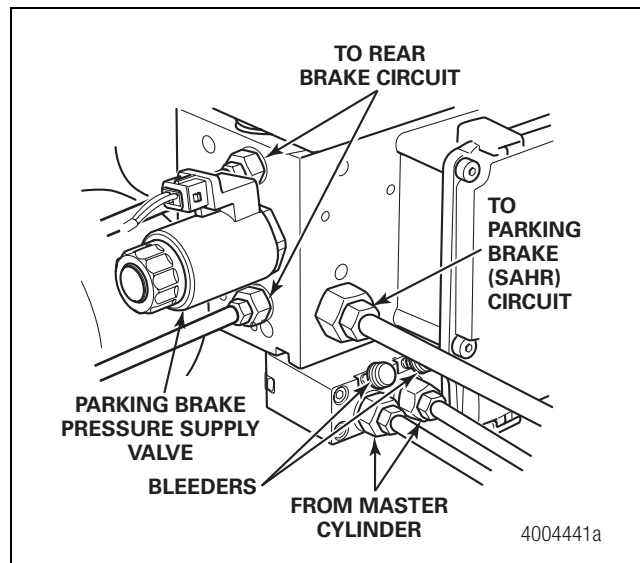

Figure 13

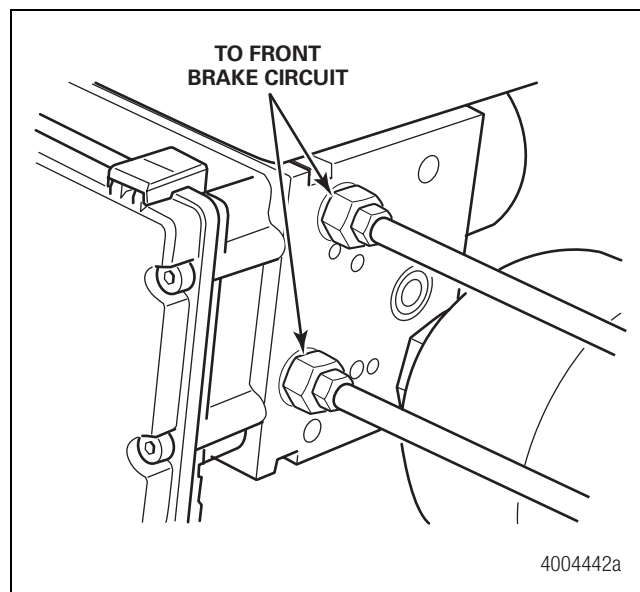

Figure 14

3. Connect the low pressure hose from the master cylinder reservoir to the HCU reservoir and secure the connection with a hose clamp. Figure 11.

4. Fill the master cylinder reservoir to the MAX mark with new clean DOT 3 or DOT 4 brake fluid from a sealed container. Refer to the vehicle specification sheet to determine which fluid to use.

⚠ WARNING

Electrical connectors must be correctly installed with the latch fully pushed in to lock the connection. If you do not securely connect and correctly latch the connectors, they can become loose or disconnected, resulting in loss of braking functions during vehicle operation or contamination of the ECU and connector.

5. First attach the 31-pin harness connector. Then, attach the two-pin power harness connector to the ECU. Push the latch into position to lock the connection. Figure 15.

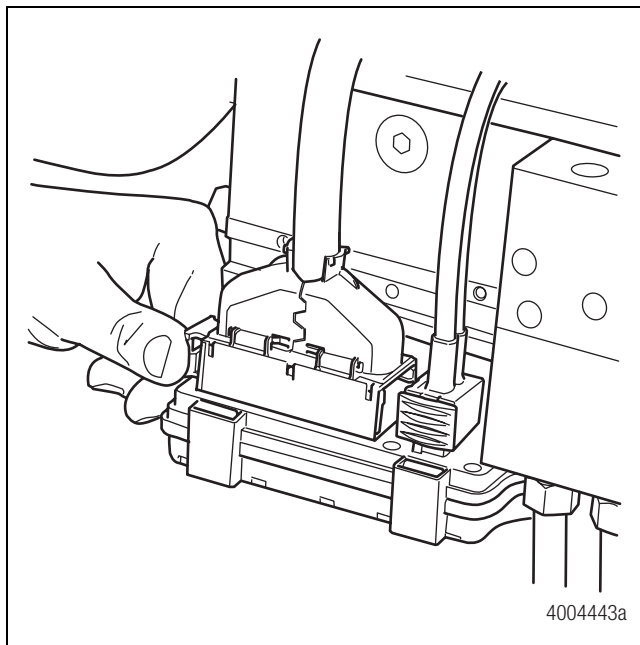

Figure 15

6. Attach the pressure supply valve connector. Figure 10.

Step 5 - Pressure Bleed the New FRK HCU and Entire HPB System

1. Fill the master cylinder reservoir to the MAX mark with new clean DOT 3 OR DOT 4 brake fluid. Refer to the vehicle specification sheet to determine which fluid to use.
2. Fit a bleeder hose onto the Spring-Applied Hydraulic Release (SAHR) canister bleeder screw and submerge the free end of the bleeder hose into the bleeder bottle.
3. Loosen the SAHR canister bleeder screw.

4. Observe the level in the master cylinder reservoir as the lower HCU reservoir fills with fluid. Continue to add brake fluid to the master cylinder reservoir to ensure the fluid level does not drop below the MIN mark.
5. When the master cylinder fluid level stabilizes and the fluid stream at the SAHR bleeder screw is clear of any air bubbles, tighten the SAHR bleeder screw.
6. Add new clean DOT 3 OR DOT 4 brake fluid to the master cylinder reservoir, if necessary, to ensure the fluid level is at the MAX mark. Refer to the vehicle specification sheet to determine which fluid to use. Continue to monitor the fluid level in the master cylinder reservoir to ensure that the level never drops below the MIN mark during the bleed procedure.
7. Install the pressure bleeder service tool adapter between the bleed equipment and the master cylinder reservoir filler neck. Ensure that the adapter is securely tightened onto the master cylinder reservoir filler neck.
8. Apply 35 psi (2.4 bar) pressure on the master cylinder reservoir with the bleed equipment.
9. Fit a bleeder hose onto one of the relay valve bleeder screws located at the HCU modulator.
10. Submerge the free end of the bleeder hose into the bleeder bottle. Note the fluid level in the bottle before you start to bleed the fluid.
11. Open the 7 mm bleeder screw until fluid begins to flow. After draining approximately 250 cc of fluid, check the stream for air bubbles. Close the bleeder screw when no more air bubbles enter the bottle.
12. Remove the bleeder hose and tighten the bleeder screw to 35-40 in-lb (4-4.5 N•m). **ⓘ**
13. Repeat the bleed procedures for the second relay valve bleeder. Continue bleeding the system with the calipers (order right rear, left rear, right front and left front), and then the parking brake SAHR. Refer to the Maintenance Manual MM-0401 for complete bleed procedures. Figure 16.

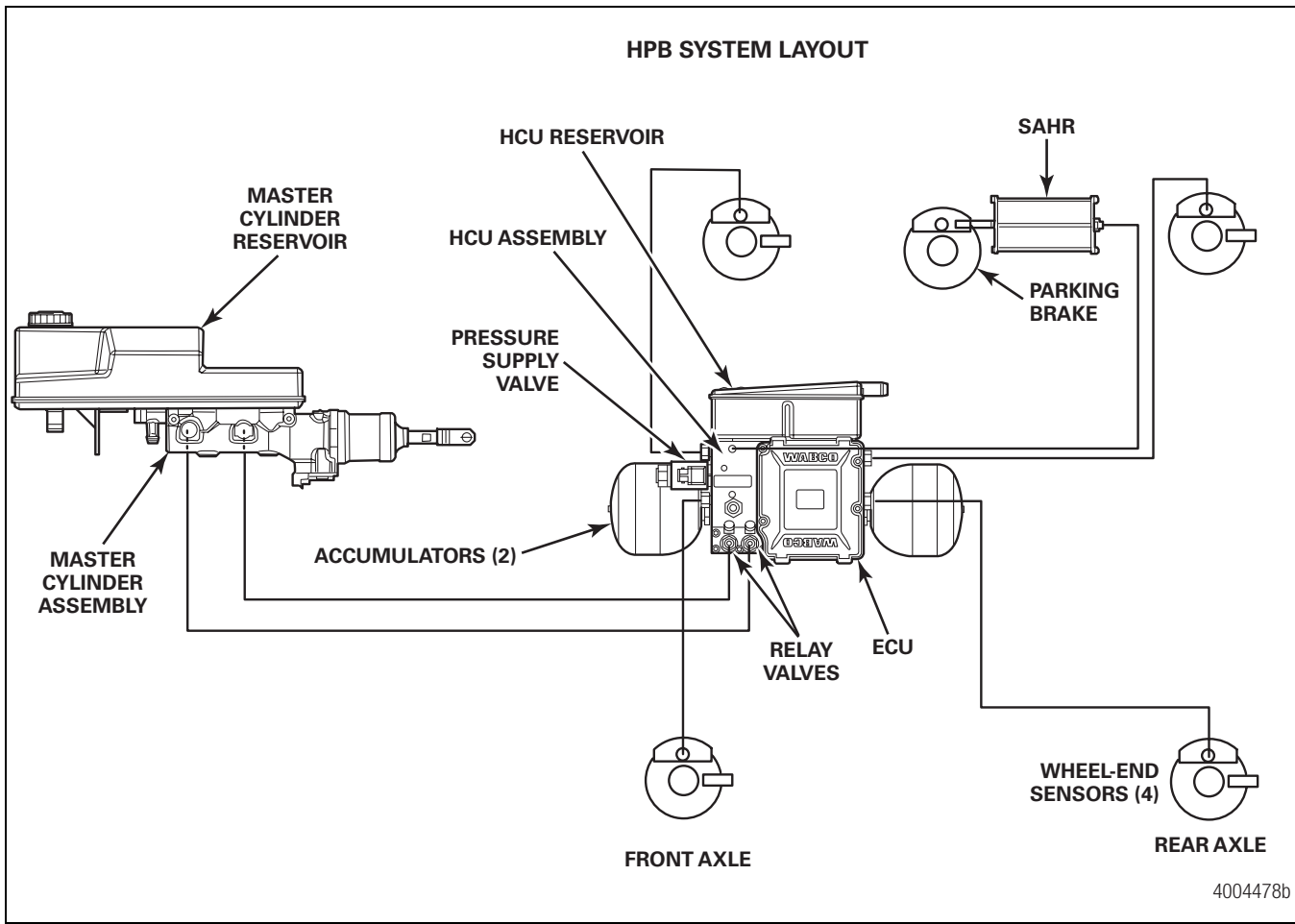

Figure 16

14. Remove the pressure bleeder service tool adapter.
15. When bleed procedure is complete, ensure the master cylinder fluid level is at the MAX level.

Step 6 - System Checkout

1. Reconnect the battery.
2. Reinstall the pressure bleeder service tool adapter between the bleed equipment and the master cylinder reservoir filler neck. Ensure that the adapter is securely tightened onto the master cylinder reservoir filler neck.
3. Apply 35 psi (2.4 bar) pressure on the master cylinder reservoir with the bleed equipment.
4. Switch the ignition ON. The pump motors will start automatically and charge the accumulators. The pump running time should be approximately 45 seconds.
5. Once pumps have stopped running, turn the ignition OFF, remove pressure and then pressure bleed equipment from master cylinder reservoir.
6. Ensure fluid in the master cylinder reservoir is at the MAX level. Reinstall master cylinder cap.
7. Turn the ignition ON. Using TOOLBOX™ Software, select the DEplete ACCUMULATORS from the End of Line pull down menu. This function will help clear any remaining air in the motor pump circuit and will run automatically after being selected.
8. Use the TOOLBOX™ Software to check that there are no active or stored faults in the HCU. If necessary, refer to Maintenance Manual MM-0401 to diagnose and resolve any remaining issues.
9. With a strong application on the brake pedal, ensure there are no leaks in the brake system.

MERITOR WABCO

Meritor WABCO Vehicle Control Systems
 2135 West Maple Road
 Troy, MI 48084-7121 USA
 800-535-5560
 meritorwabco.com

Information contained in this publication was in effect at the time the publication was approved for printing and is subject to change without notice or liability. Meritor WABCO reserves the right to revise the information presented or to discontinue the production of parts described at any time.

Copyright 2008
 ArvinMeritor, Inc.
 All Rights Reserved

Printed in USA

TP-0913
 Issued 12-08
 (16579/22882)